



2026 BMi

COMPANY PROFILE

**Shaping Tomorrow with Technology
Building Global Partnerships on Innovation and Trust**

Pioneering Innovation and Growth in Automation Solutions

Table of Contents

1. COMPANY OVERVIEW

Introduction to BMI Co., Ltd., including corporate background, founding year, key milestones, and organizational structure.

2. FACTORY OVERVIEW

A presentation of our factory scale, facilities, and advanced infrastructure.

3. FACTORY AUTOMATION

A showcase of BMI Co., Ltd.'s expertise in automation equipment, featuring major project achievements and capabilities.

4. CERTIFICATION & STANDARDS

A presentation of BMI Co., Ltd.'s key domestic and international certifications and examples of recognized technical excellence.

01

COMPANY OVERVIEW



01 | COMPANY OVERVIEW

Company Overview

Established in 1997, BMI Co., Ltd. has over 30 years of experience designing and supplying equipment to steel mills worldwide.

Since 2015, we have expanded into engine, transmission, and secondary battery equipment through our Automation Division, delivering advanced solutions to major global companies.

With expertise in steel and automation systems, BMI Co., Ltd. leads the way in smart factory innovation, striving to be a global technology leader.

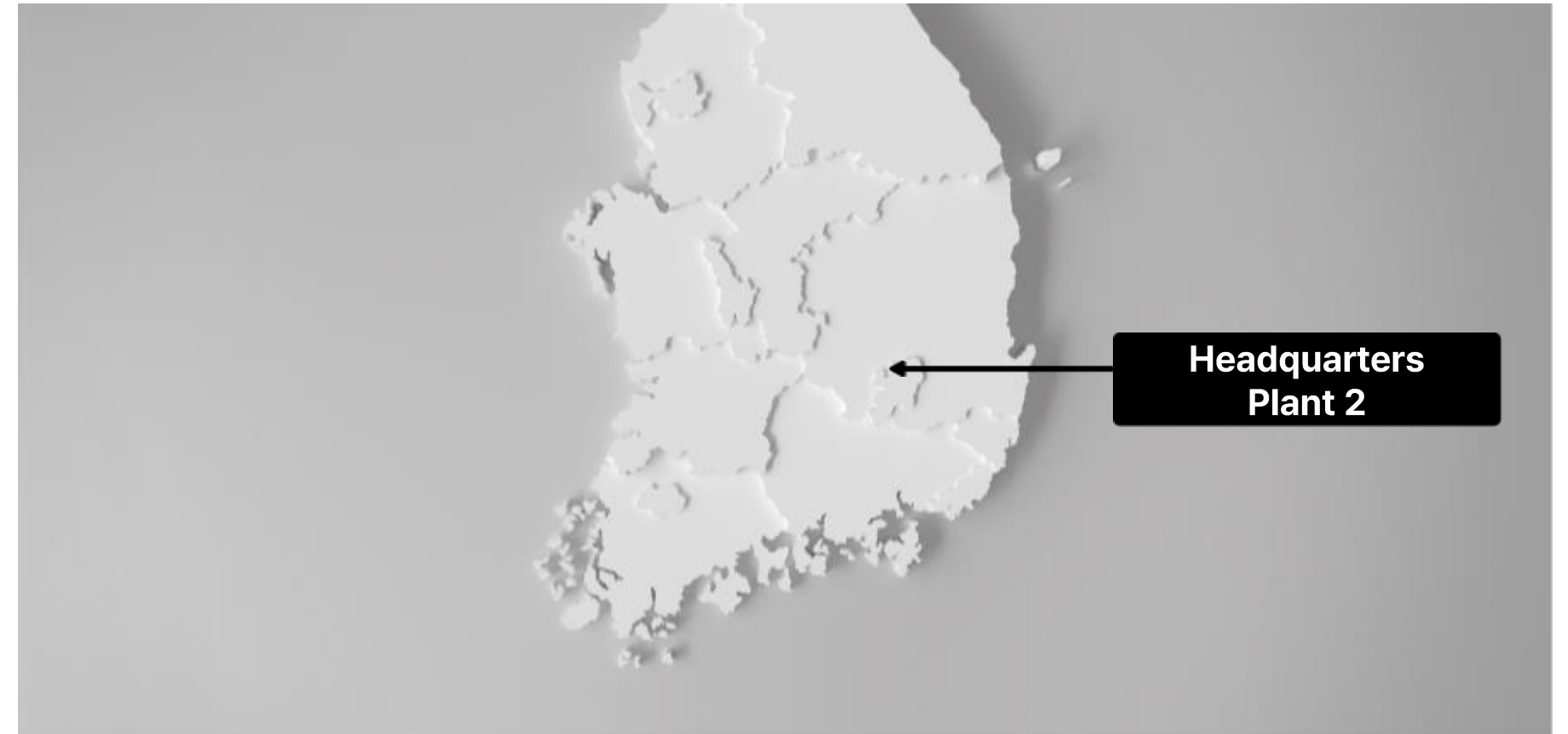

Company	BMI Co., Ltd.
CEO	Sangyoon Lee
Website	http://www.bm-i.co.kr
Address	86, Dalseong 2-cha 1-ro, Guji-myeon, Dalseong-gun, Daegu, Korea

Employees	36 (as of 2026)
Founded	September 1, 1997
Revenue	KRW 13.6 billion (as of 2024)
Capital	KRW 225 million

01 | COMPANY OVERVIEW | Milestones

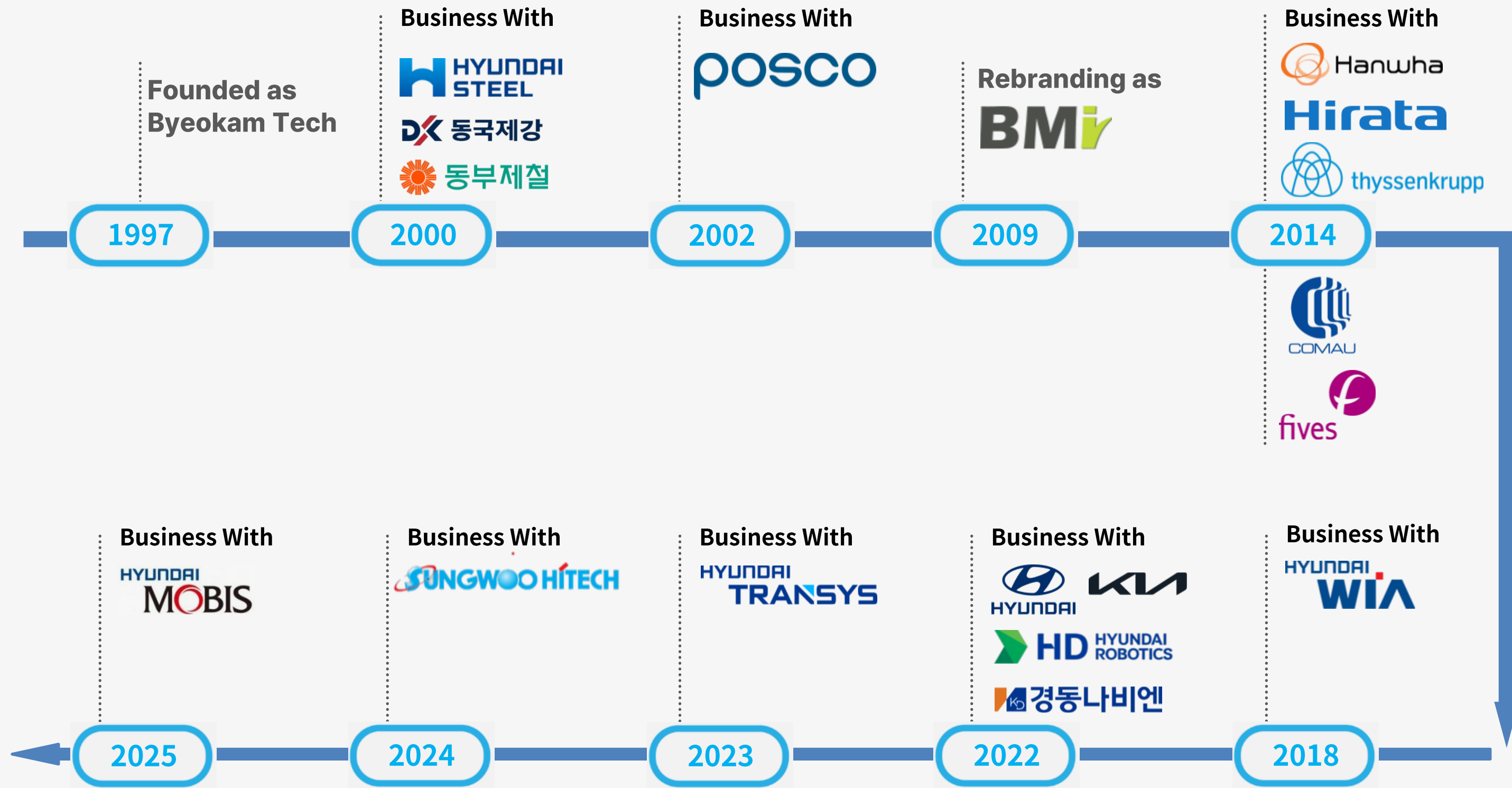

01 | COMPANY OVERVIEW | Organization Chart

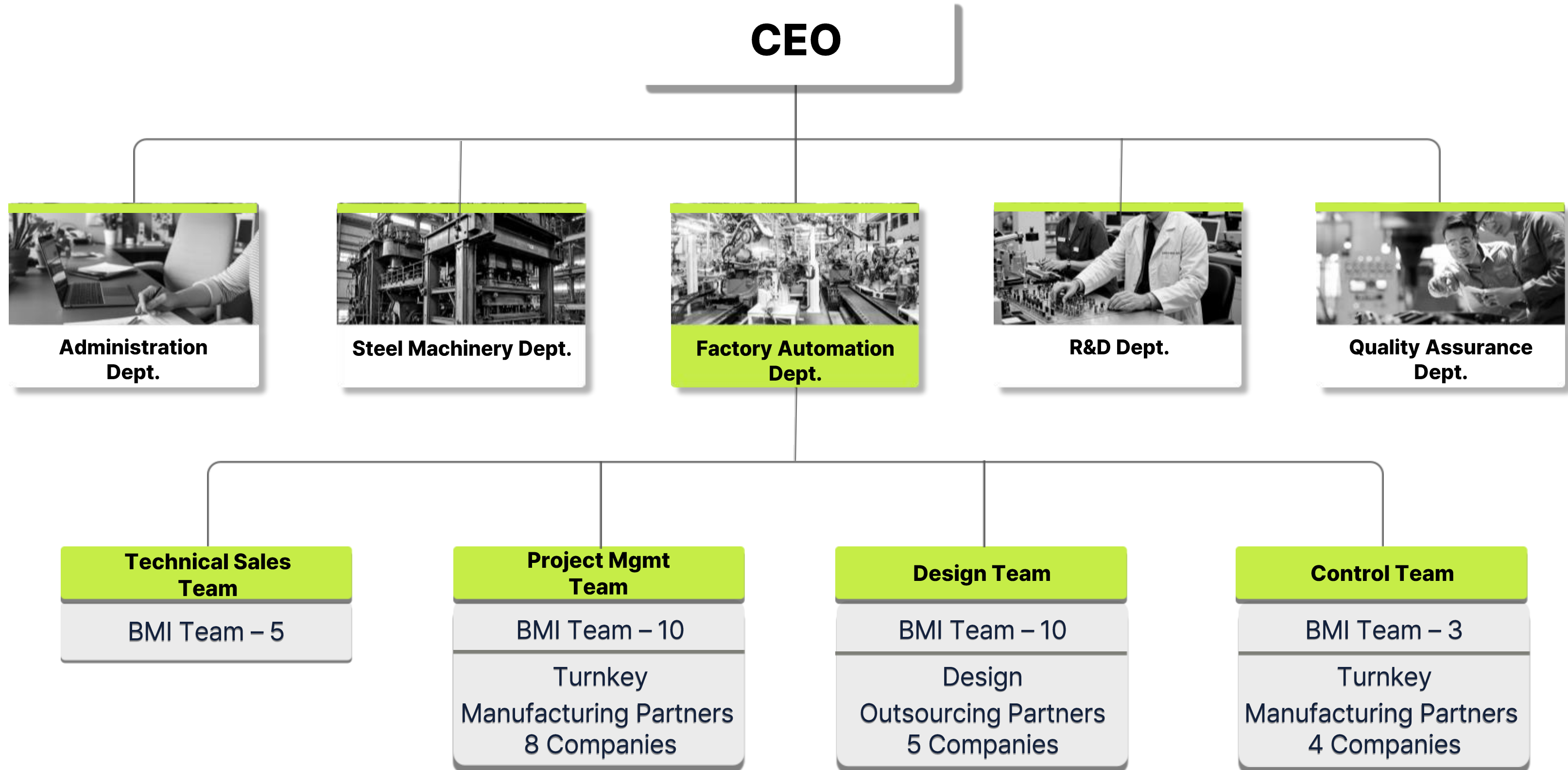

02

FACTORY OVERVIEW

02 | FACTORY OVERVIEW | Layout Headquarters

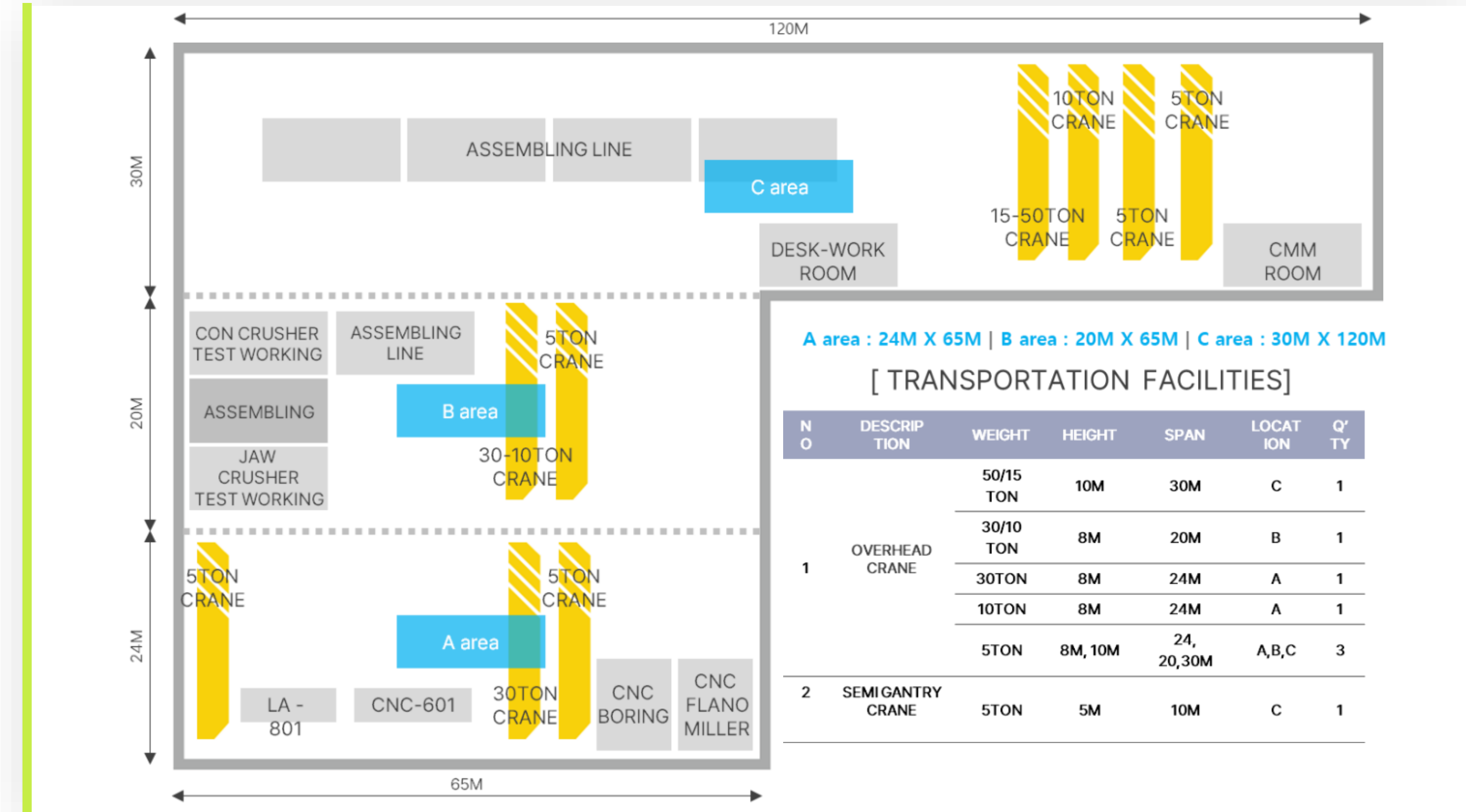

02 | FACTORY OVERVIEW | Layout

Plant 2

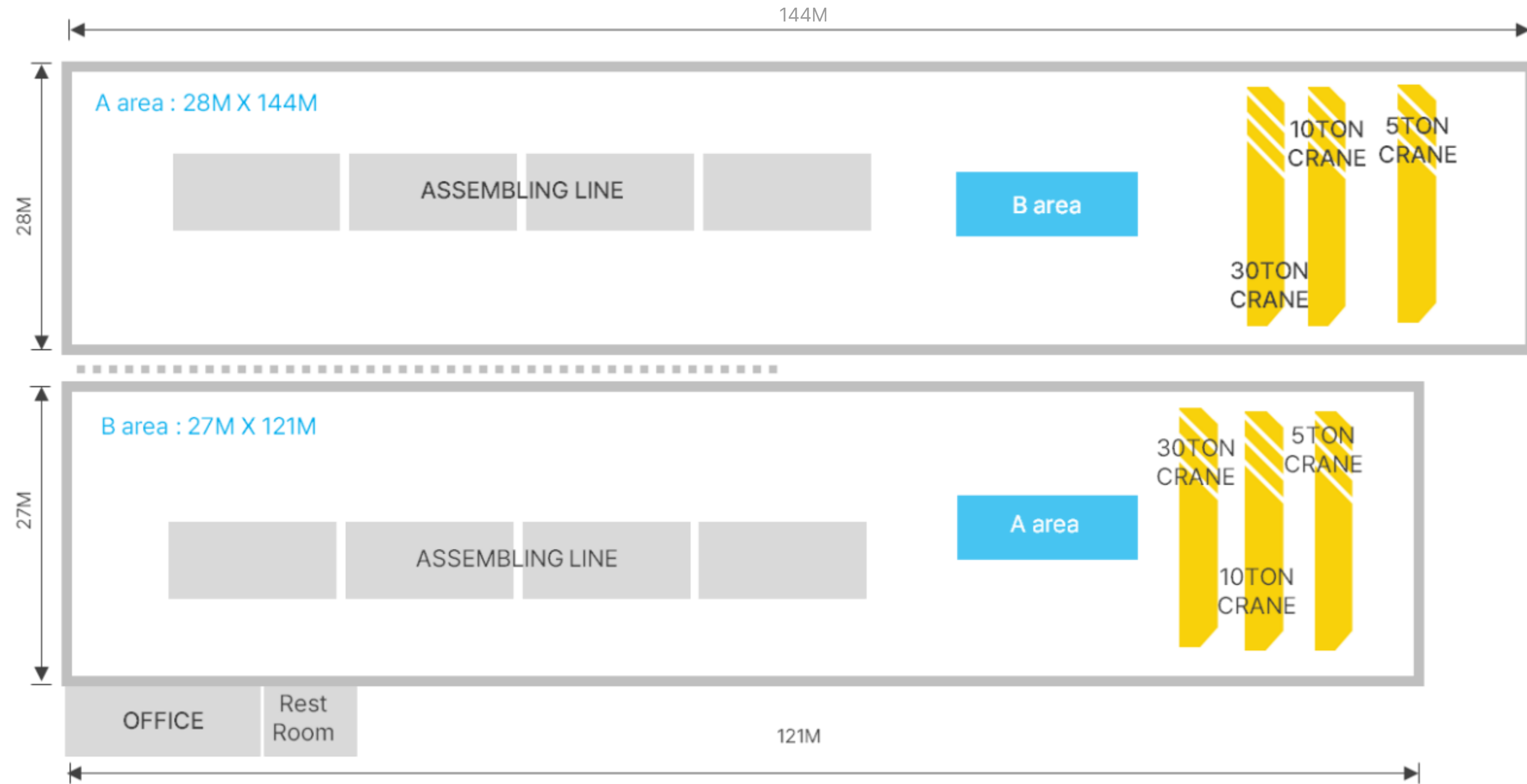

[TRANSPORTATION FACILITIES]

OVERHEAD Crane

- 5TON : 2 SET(A & B), - 10TON : 2 SET(A & B), - 30TON : 2 SET(A, B)

02 | FACTORY OVERVIEW | Measuring Equipment

COORDINATE MEASUREMENT MACHINE (3D)



CONTURA G2

MAKER	ZEISS, GERMAN
MACHINE NAME	CONTURA G2
MEASURING RANGE	X=1000mm (39.3 in) Y=1200mm (47.2 in) Z=600mm (23.6in)
ISO 10360-2	MPE_E = (1.8 + L/350) μm
PROBE	XDT TL3

03

FACTORY AUTOMATION

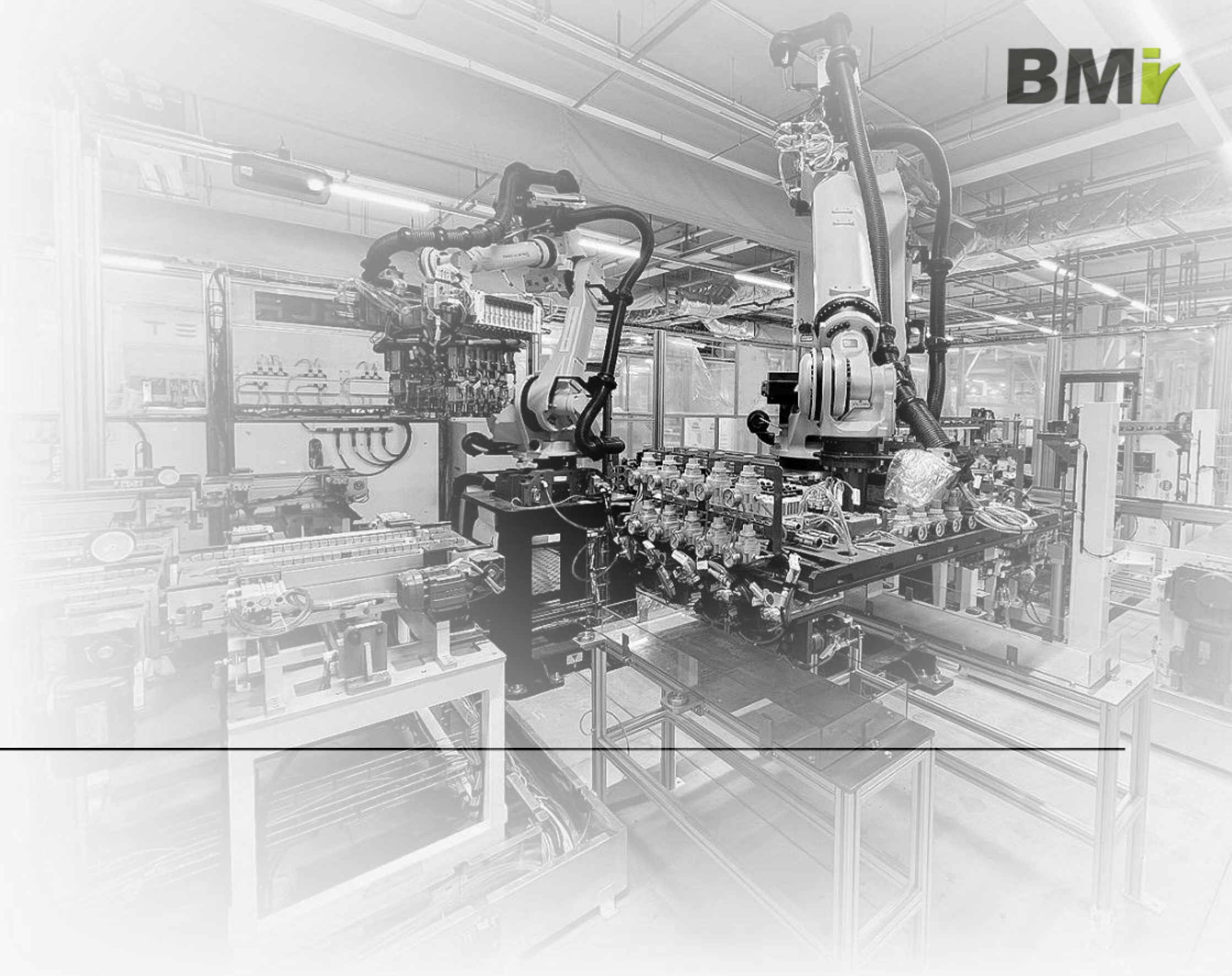







2015

NO	PROJECT	VOLUME	CUSTOMER
1	GF9 Site1 – Transmission Dial Index Machine	5 St	
2	Ford – Test Line Pallet	400 Set	
3	PTA Test Line – Oil Inject M/C & Conveyor	2 St	



2016

NO	PROJECT	VOLUME	CUSTOMER
4	CVT – Transmission Sub Assembly Line	9 St	
5	SGM CSS – Engine Cylinder head Assembly Line	8 St	
6	GF9 Site3 – Transmission Dial Index Machine , etc	13 St	
7	PTA – T7 Leak Test Machine & Conveyor	1 Set	

2017

NO	PROJECT	VOLUME	CUSTOMER
8	PTA – Buffer Conveyor	1 Set	 HYUNDAI POWERTECH
9	Battery Assembly Pallet	4 Set	 fives
10	Cylinder Head Machining Jig	5 Set	 fives
11	Ford – RGV Pallet	100 Set	 thyssenkrupp
12	Site2 – Engine Assembly Line - Torque to turn Test M/C	4 St	 Hirata
13	CVT – Transmission Mian Assembly Line	10 St	 Hirata
14	GM Brazil – Engine Cylinder head Assembly Line	12 St	 Hanwha

2018

NO	PROJECT	VOLUME	CUSTOMER
15	FCA - SIVET Main & Test line pallet	80 Set	 fives
16	ZF - Sub line Pallet	30 Set	 thyssenkrupp
17	Assembly Pallet	300 Set	Hirata
18	AW - China F4 Transmission Assembly Line	29 St	Hirata
19	AW - China F5 Transmission Assembly Line	29 St	Hirata
20	HLGP - OS EV Battery Pack Assembly Line (BPA)	22 St	 Hanwha
21	PTA - Buffer Conveyor, etc	1 Set	HYUNDAI POWERTECH







2019

NO	PROJECT	VOLUME	CUSTOMER
22	LUCID – Battery Assembly Pallet	50 Set	
23	FORD – Transmission Sub line Pallet	150 Set	
24	Gear Press M/C, etc	1 Set	Hirata
25	Stator Assembly Line	7 St	Hirata
26	Hyundai Motor – Ulsan Factory#2 DCT AWD Alternative	1 Set	
27	Hyundai Transys – Collaborative Robot	1 Set	









2020

NO	PROJECT	VOLUME	CUSTOMER
28	AW FR9 (LA) Transmission Assembly Line	12 St	Hirata
29	FR9 Transmission Assembly Line	24 St	Hirata
30	HLGP – DN8 12V Battery pack Line	9 St	HD HYUNDAI ROBOTICS
31	Hood Assembly Line	10 St	경동나비엔
32	Scout Laser Welding machine	2 St	경동나비엔

2021

NO	PROJECT	VOLUME	CUSTOMER
34	TESLA – Battery System Assembly Line	Line	 Hanwha
35	Company M – NE EV Stator Line (Phase 4)	5 St	 Hanwha
36	Company S - CVT Assembly Line	18 St	Hirata
37	Company A Transmission – Dial Index Station (Carrier Assembly)	4 Cell	Hirata
38	Main Assembly Line 5	Line	 NAVIEN
39	VALVE BODY – Auto Feeding system	1 St	 HYUNDAI
40	HMC Ulsan Plant Transmission Branch Rationalization Project	1 Set	 HYUNDAI
41	HMC Ulsan Plant 3 6-Speed Transmission Assembly Line Modification Project	1 Set	 HYUNDAI
42	TESLA – Battery System Assembly Line_Retooling	Line	 Hanwha

2022

NO	PROJECT	VOLUME	CUSTOMER
43	MES Implementation Project	Line	 NAVIEN
44	Movable Platform Control	3 St	 HYUNDAI STEEL
45	GOONJA Farm Automation Project	Line	 GOONJA FARM
46	Heat Exchanger Top Coating Machine	2 St	 NAVIEN
47	Air-Proportional Gas Valve Automatic Fastening Machine	2 St	 NAVIEN
48	HTS Main Assembly Line for EV Motor Gearbox	Line	 HYUNDAI WIA
49	HMC Ulsan Plant 6-Speed Factory 1 Economic Model Modification	1 Set	 HYUNDAI
50	HMC Ulsan Plant New Small Manual Transmission Assembly Line Quality Improvement and Rationalization Modification	1 Set	 HYUNDAI

2023

NO	PROJECT	VOLUME	CUSTOMER
51	HDM Motor-Gearbox PE System Line	Line	
52	CUMMINS – Vacuum chamber	10 St	
53	HMC Ulsan Plant 6-Speed Transmission Assembly Line Modification for Factory 1	1 St	
54	Company G -BEV SITE 3_SUB LINE TOTAL	Line	
55	TESLA – GFBB Coyoyte Project	Line	
56	LGES Raw Material Packaging and Logistics Line	Line	
57	Single Vacuum Chamer	4 St	







03 | FACTORY AUTOMATION | Track Record



2024

NO	PROJECT	VOLUME	CUSTOMER
58	Prismatic Cell BSA Development Project	2 St	
59	UZ T-CAR BSA Assembly Line	Line	
60	DK68 CH Line	1 St	
61	New Small MT Assembly Line Model Addition	1 Set	
62	NQ5 Main Line Model Addition	1 Set	
63	DK68 CH Pallet	100 Set	
64	BC4T T-CAR BMA BPA Assembly Line	Line	
65	CNC Washer	3 St	
66	Single Vacuum Chamber	2 St	

2025

NO	PROJECT	VOLUME	CUSTOMER
67	NQ6 HEV BPA pre-development project	Line	 SUNGWOOHITECH
68	Single Vacuum Chamber	1 St	 fives
69	Mobis adds 4-line large-diameter stator and 2-line impregnation models	Line	 HYUNDAI MOBIS
70	Hyundai Motor Company adds TMED models to its rear-wheel drive mainline	Line	 HYUNDAI
71	Tesla GFBB BEN Repack Line	Line	 Hanwha
72	NE2 Preliminary T-CAR Development Project	Line	 SUNGWOOHITECH
73	GM PHEV GRx Main Asssembly Line	Line	 Hanwha
74			
75			

PE System Line

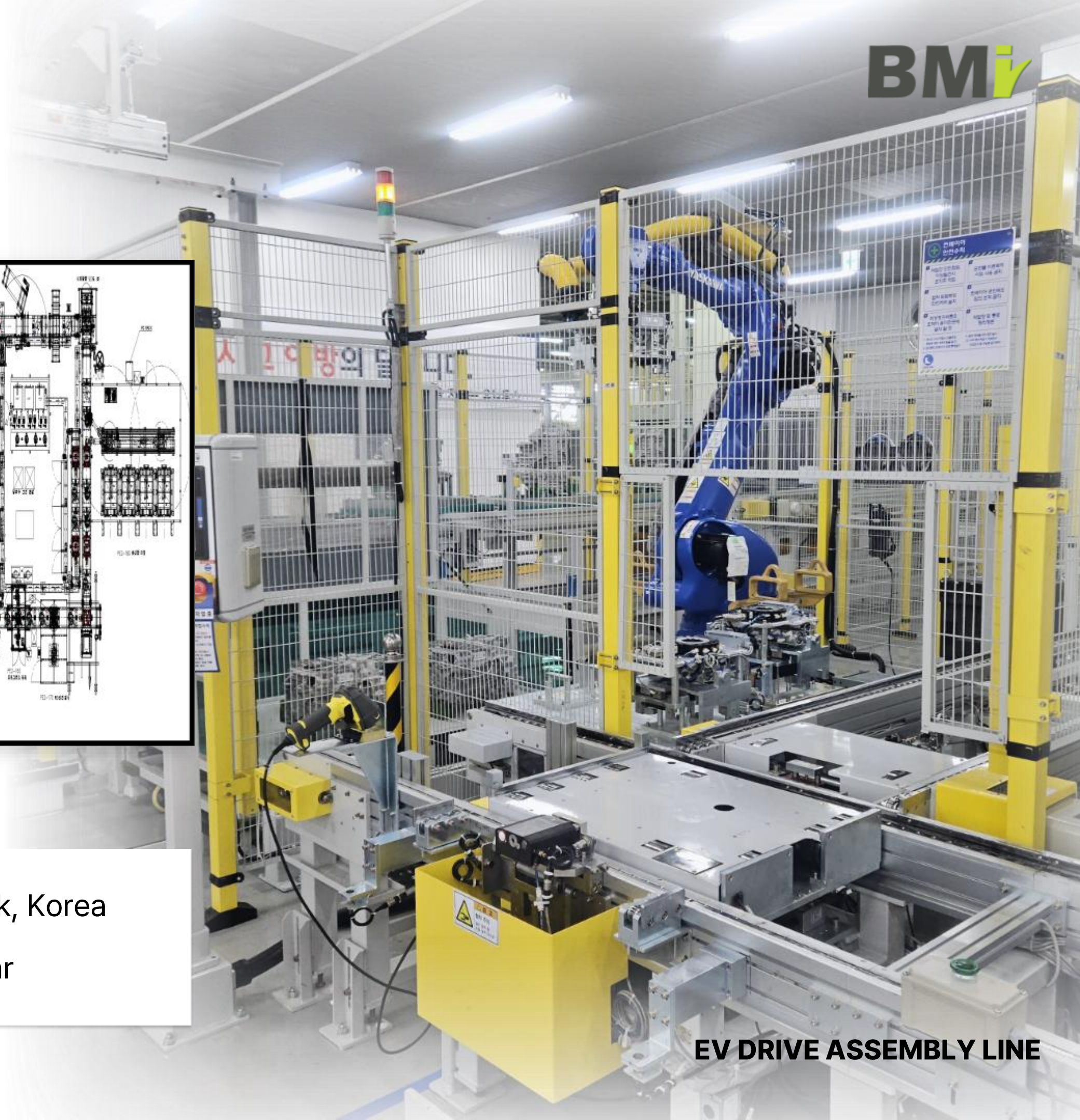
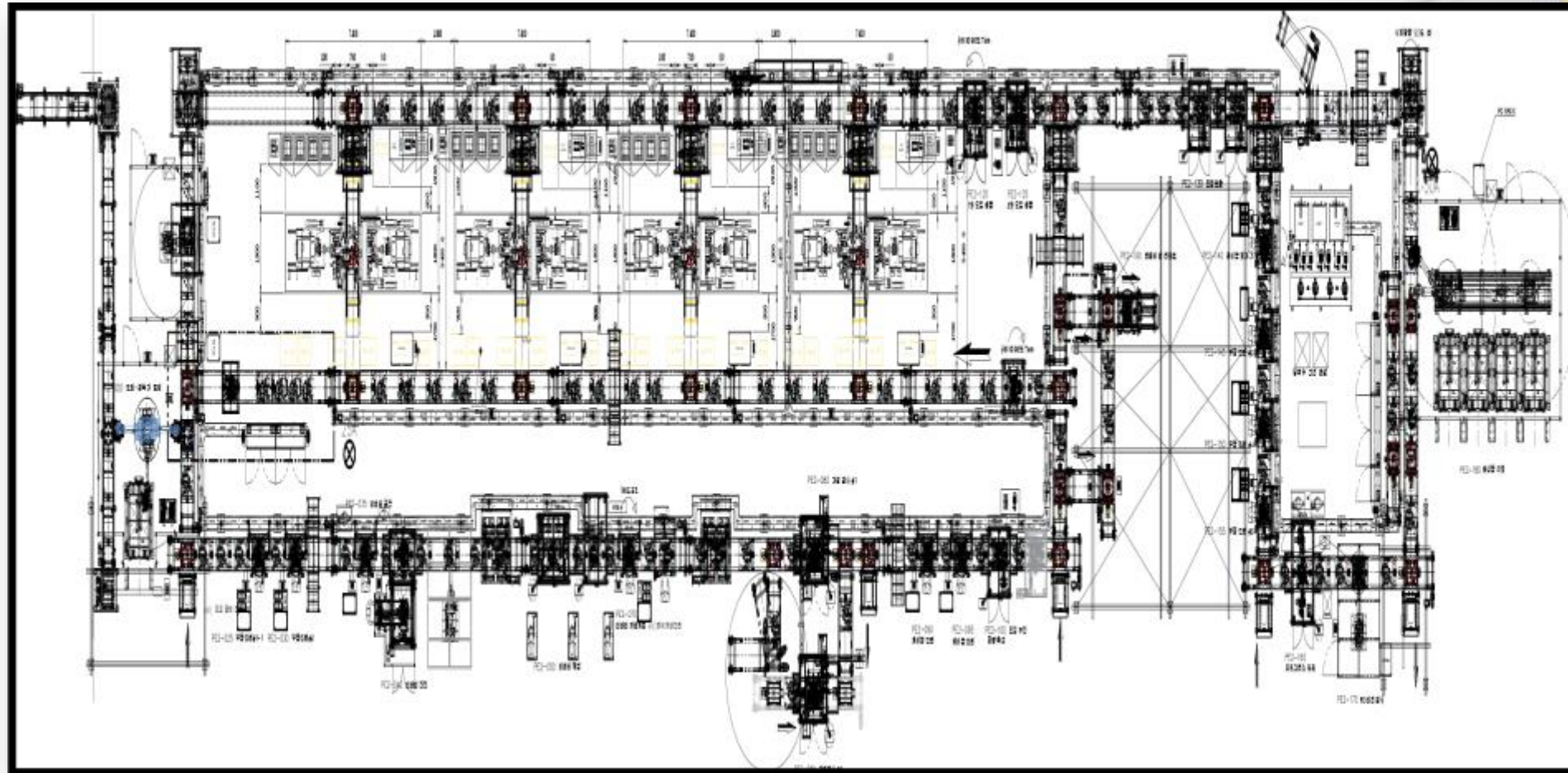

CUSTOMER	Company M	SITE	Pyeongtaek, Korea
CYCLE TIME	120 SEC	VOLUME	100 K / Year

EV DRIVE ASSEMBLY LINE

EV Motor Gearbox Main Assembly Line

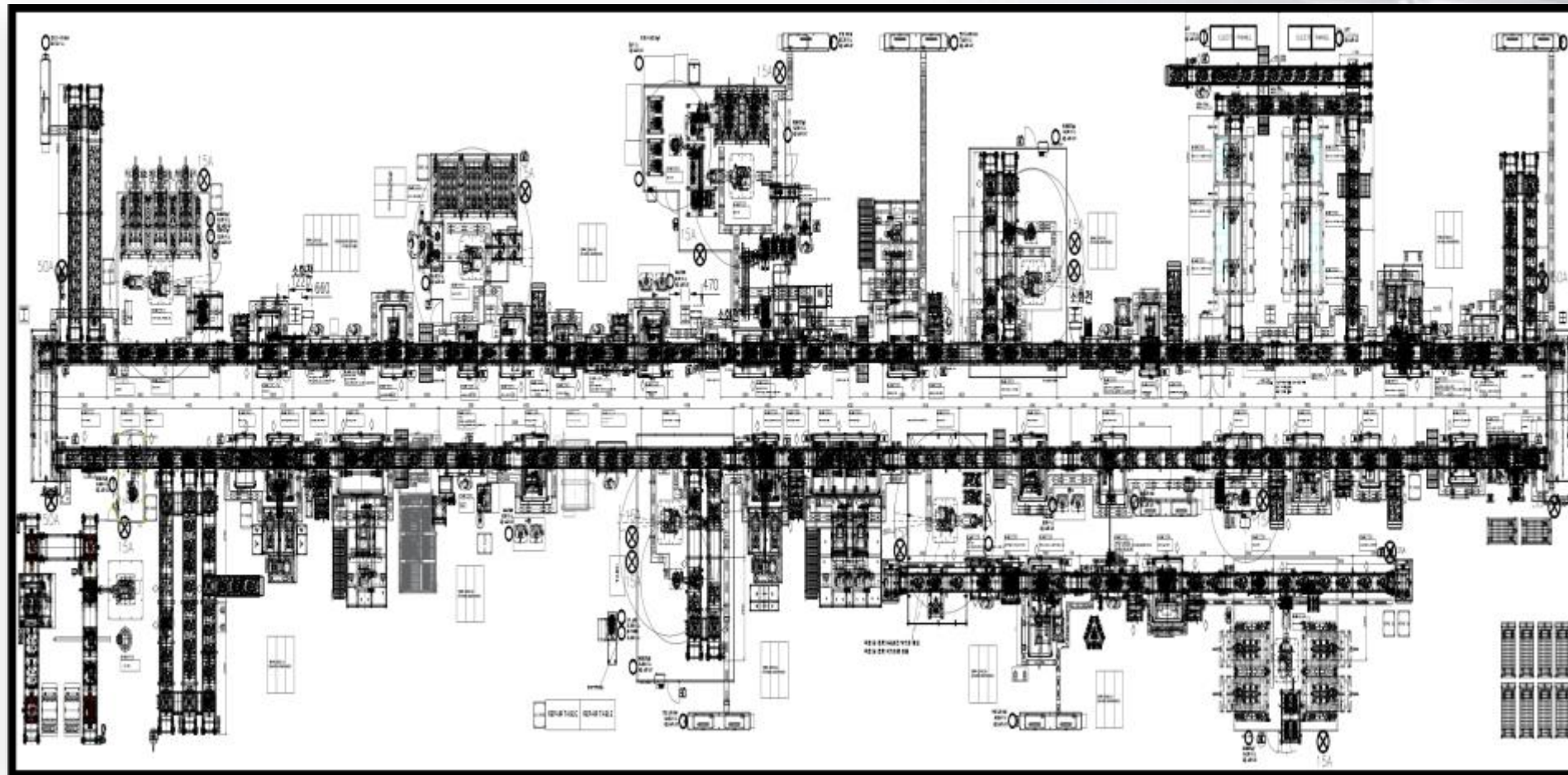

CUSTOMER	Company M	SITE	Pyeongtaek, Korea
CYCLE TIME	58 SEC	VOLUME	200 K / Year

NE EV STATOR LINE (Phase 4)

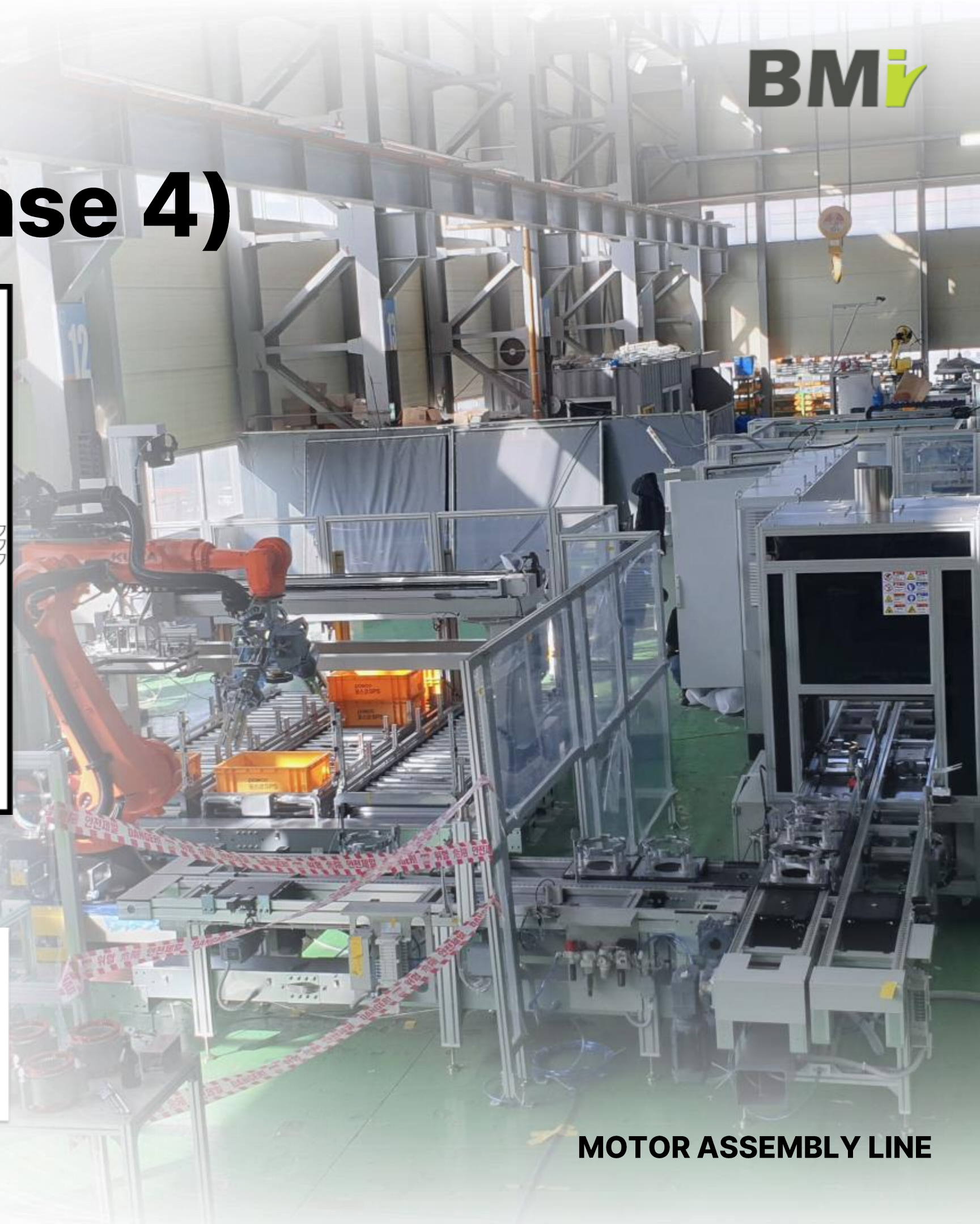
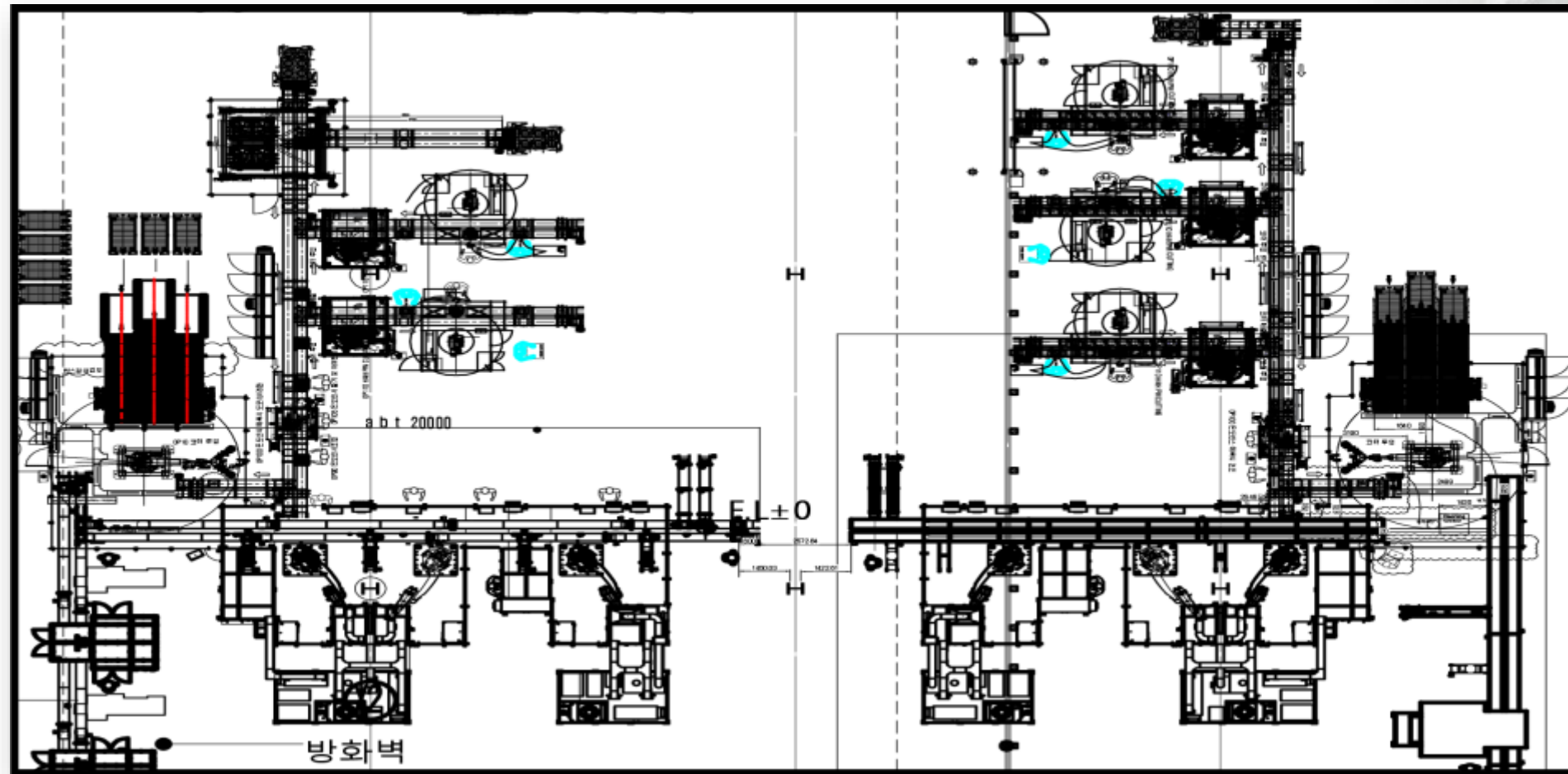

CUSTOMER	Company H	SITE	Daegu, Korea
CYCLE TIME	95 SEC	VOLUME	5 Units

GM – Engine Assembly Line

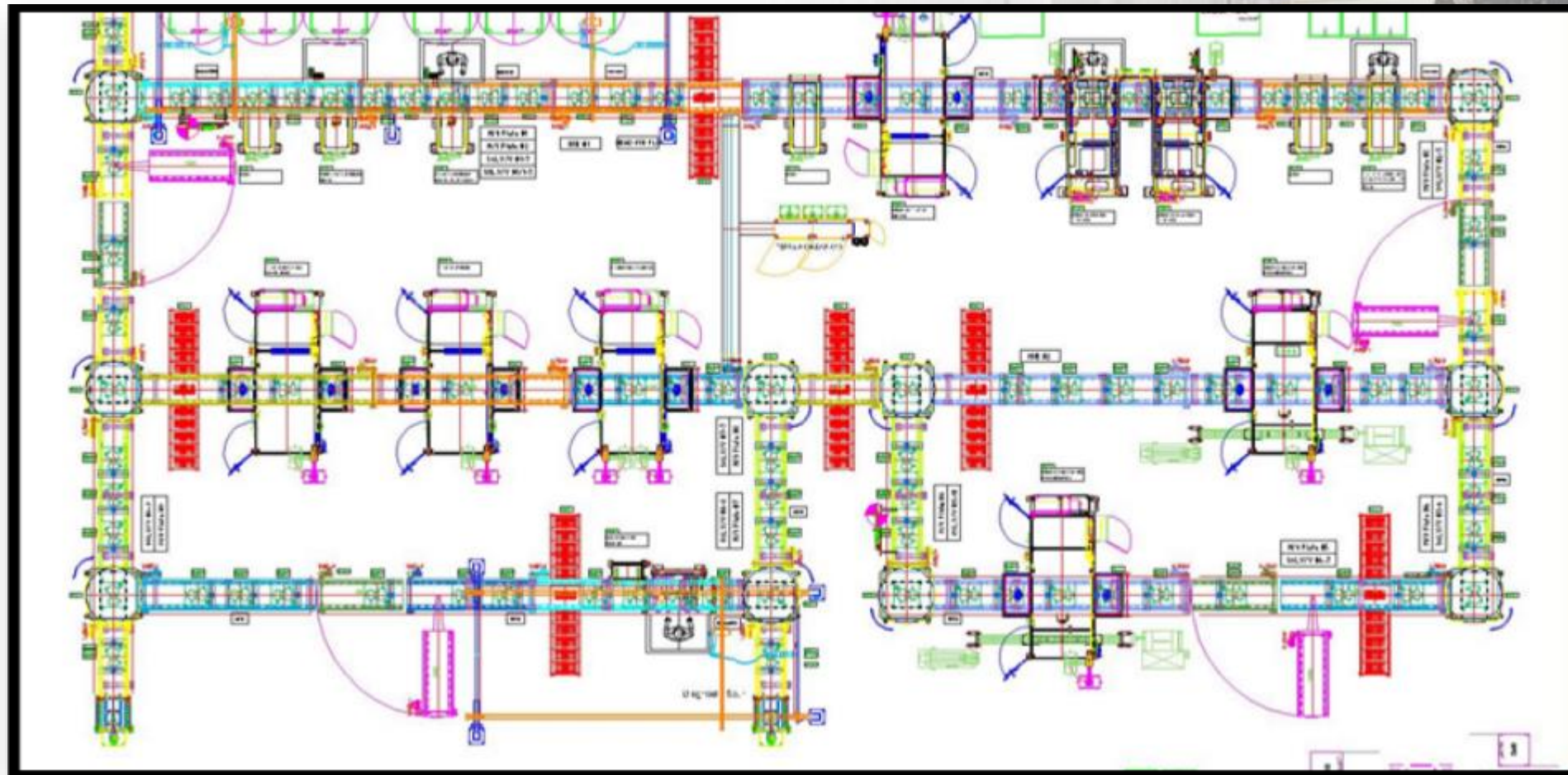

CUSTOMER	Company H	SITE	GM Brazil
CYCLE TIME	56 SEC	VOLUME	Cylinder Head Line

ENGINE ASSEMBLY LINE

GFBB Coyote Project

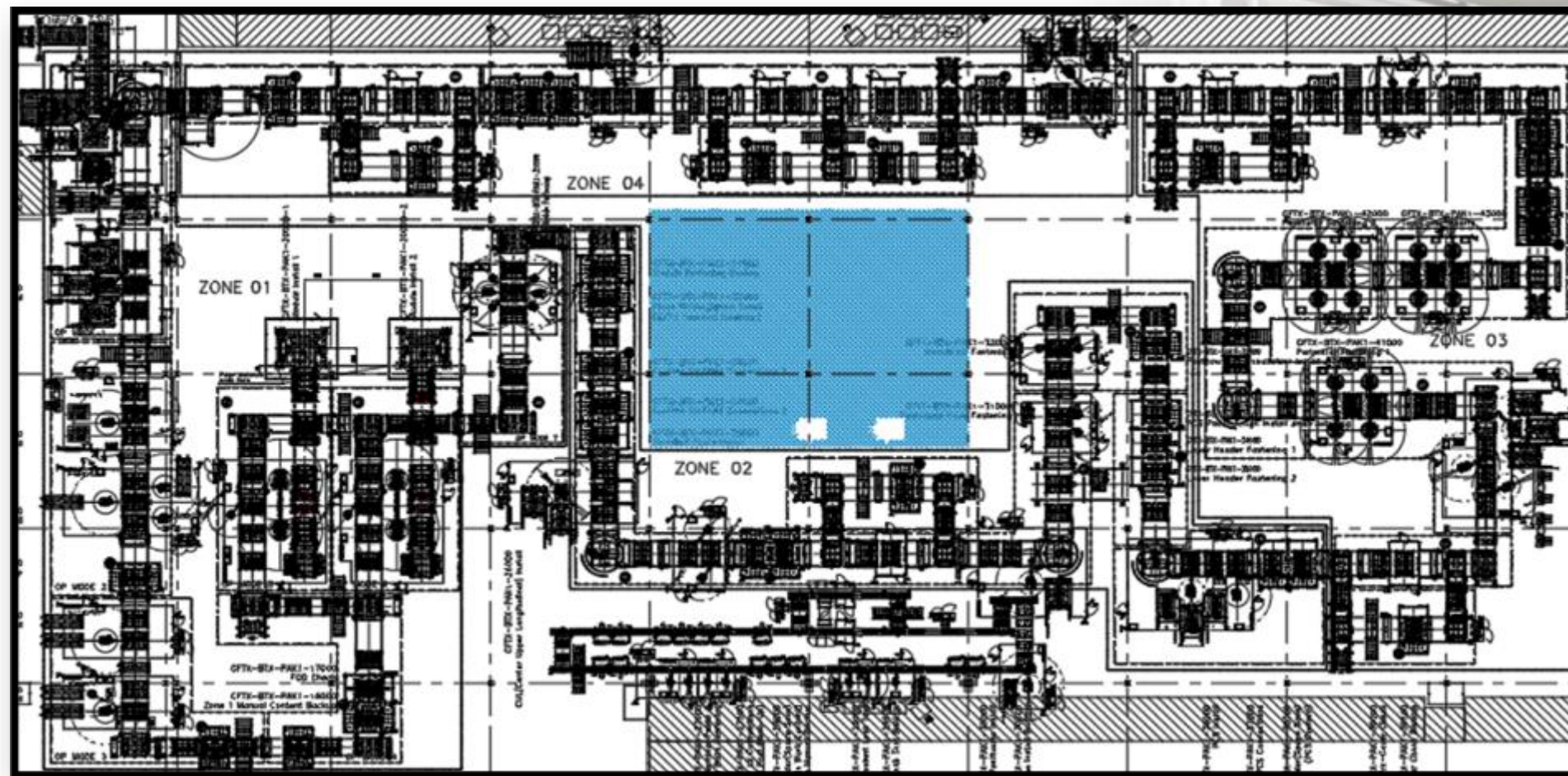

CUSTOMER Company H

SITE Germany

CYCLE TIME - SEC

VOLUME -K / Year

BATTERY PACK ASSEMBLY LINE

GFTX - BSA Line

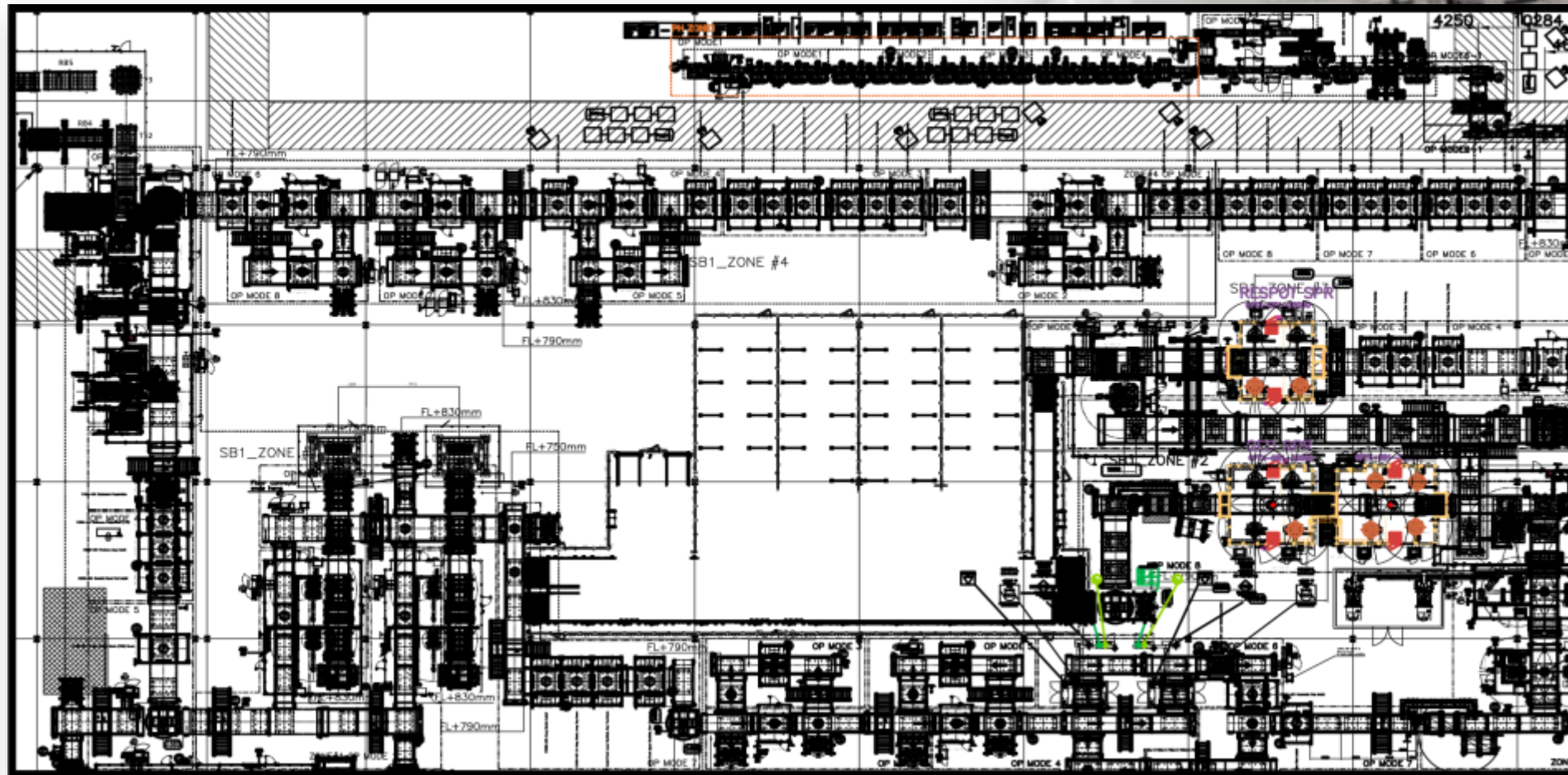

CUSTOMER	Company H	SITE	Austin, Texas, USA
CYCLE TIME	30 SEC	VOLUME	BSA Main Assembly Line

BATTERY PACK ASSEMBLY LINE

Packaging Section of Main Line 5

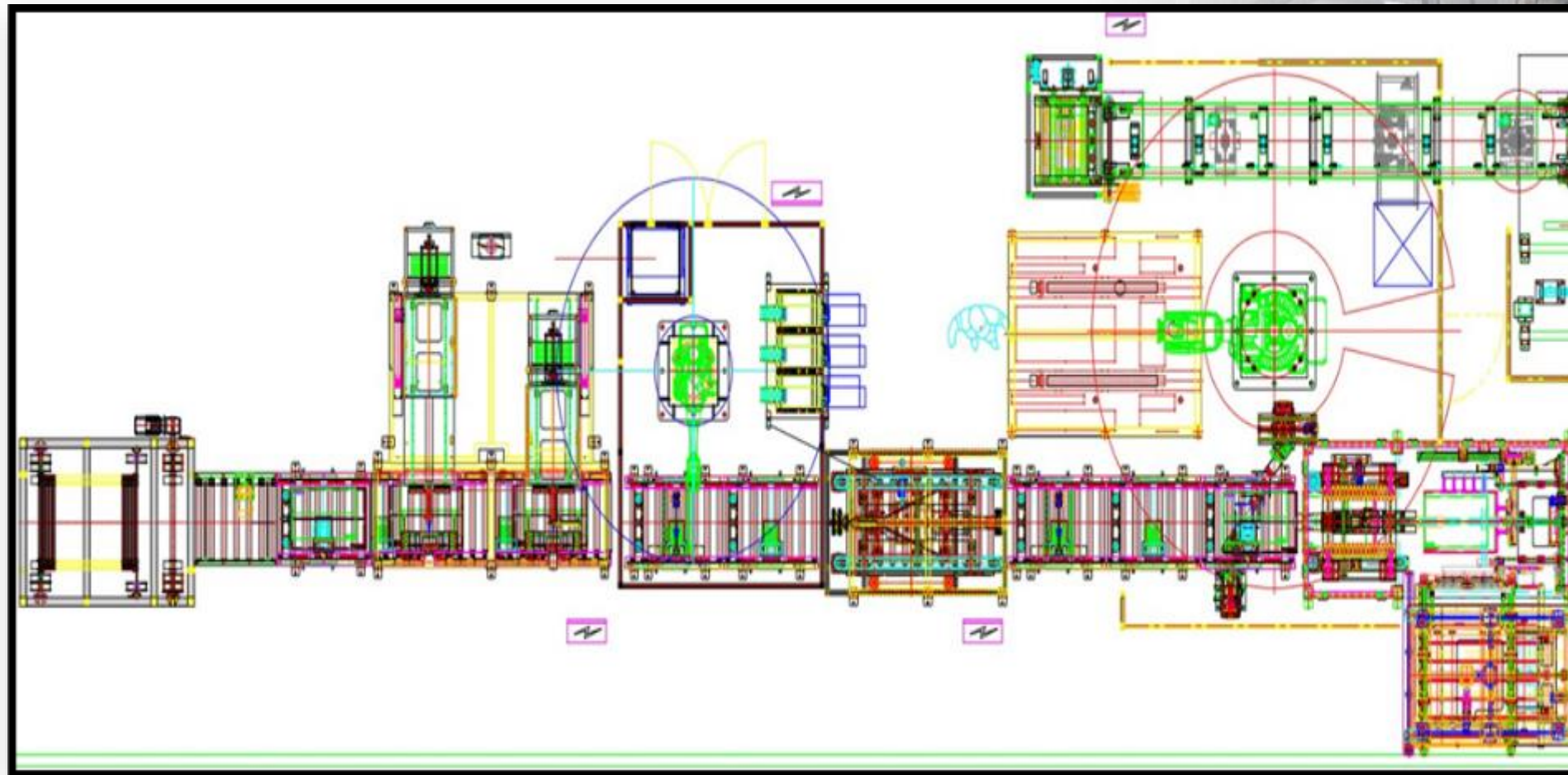

CUSTOMER Company K

SITE Osan, Korea

CYCLE TIME 60 SEC

VOLUME 200K / Year

Formation Line Elevator (Motor Lifter)

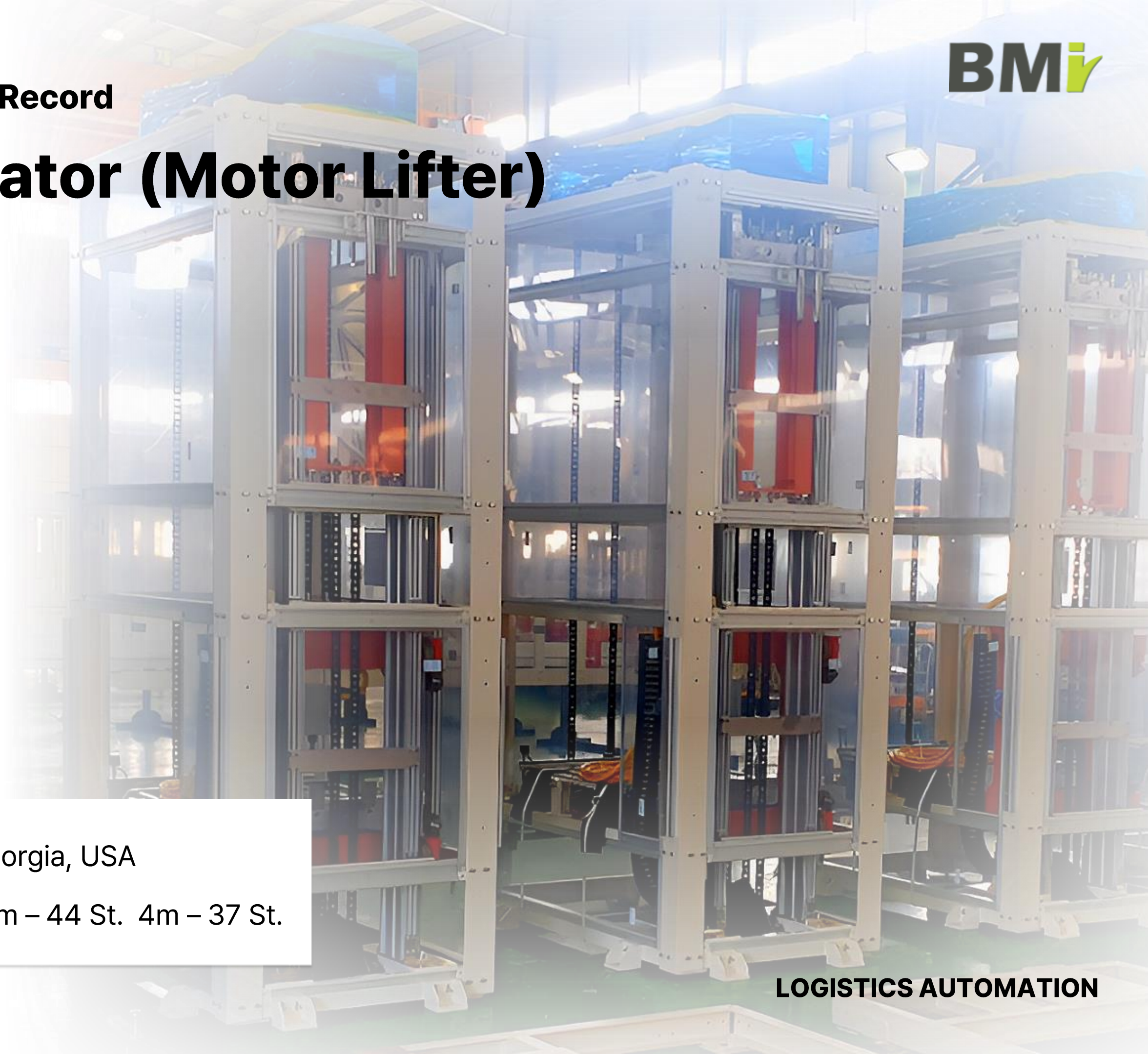
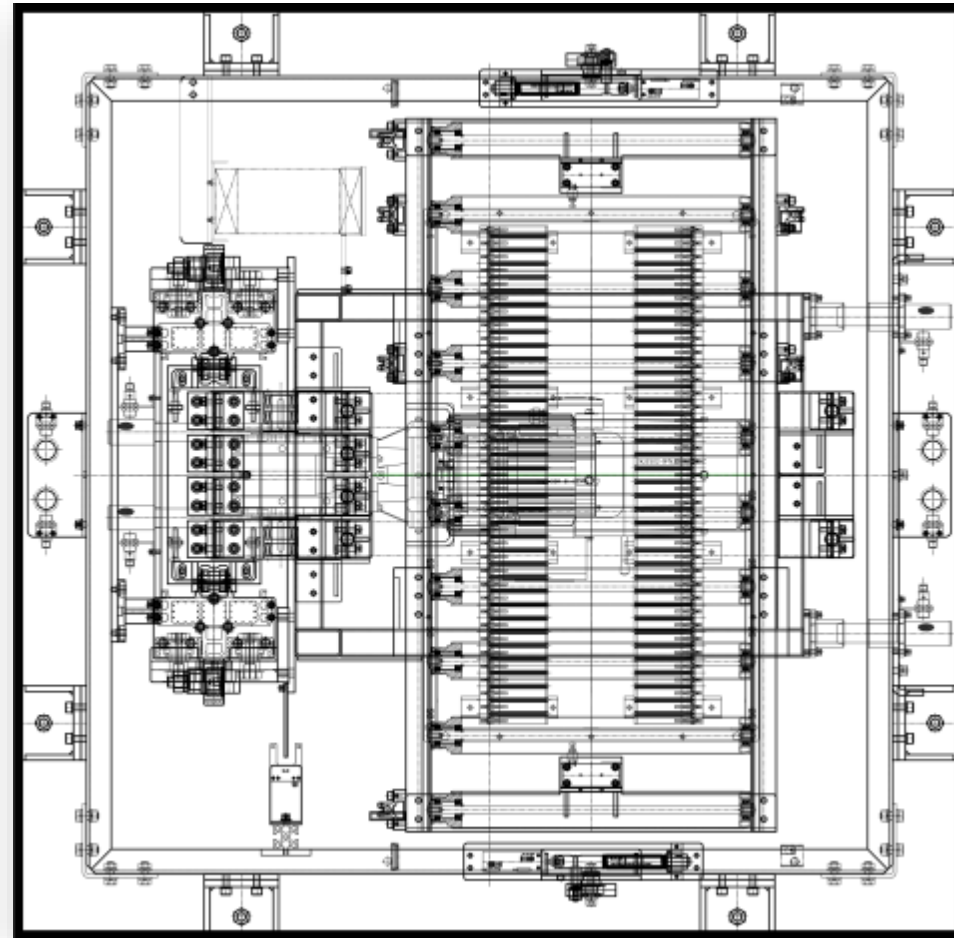

CUSTOMER	Company H	SITE	Georgia, USA
CYCLE TIME	-	VOLUME	15m – 44 St. 4m – 37 St.

04

Steel Machinert

Posco E&C CCM Machine



CCM MACHINE



CCM MACHINE

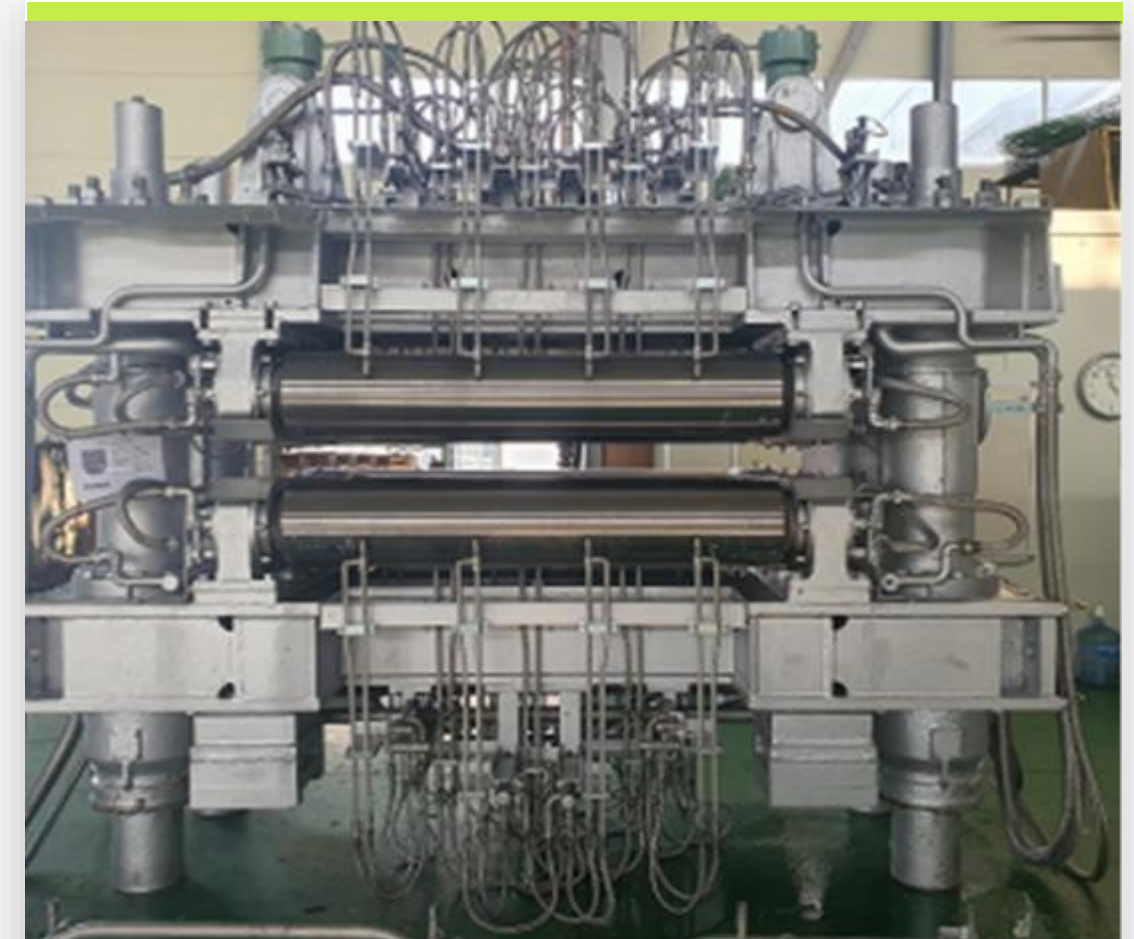

CCM MACHINE

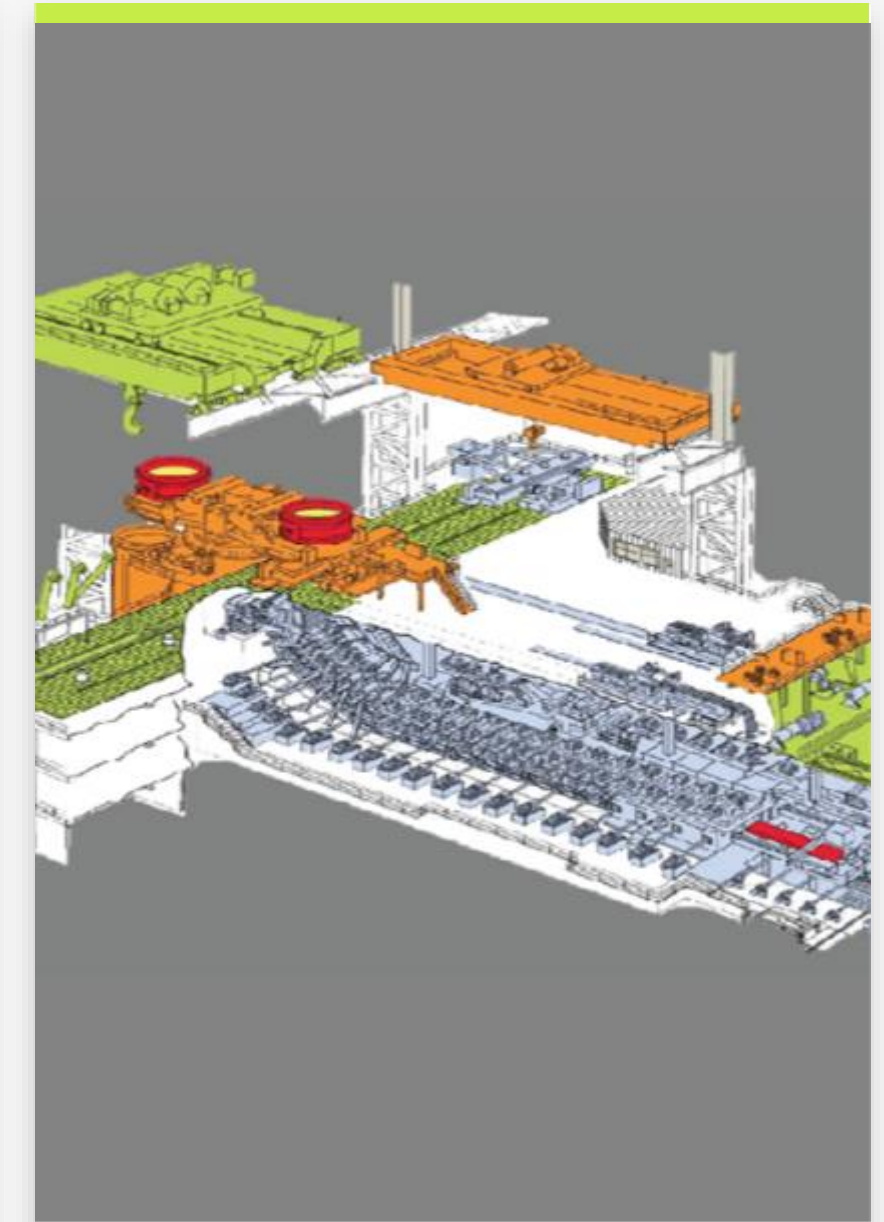
CONTINUOUS CASTING PLANT**SLAB DUMMY BAR****400X520X140
BEAM BLANK SEGMENT****MOULD & OSCILATOR
LOCALIZATION
(POSCO)****LAYOUT**

STEELMAKING PLANT



#1



#2



#3



#4

#1

80Ton Electric Furnace Low Shell

#2

150Ton Electric Furnace

#3

80Ton Electric Furnace Gantry

#4

120Ton LF Ceiling Mast

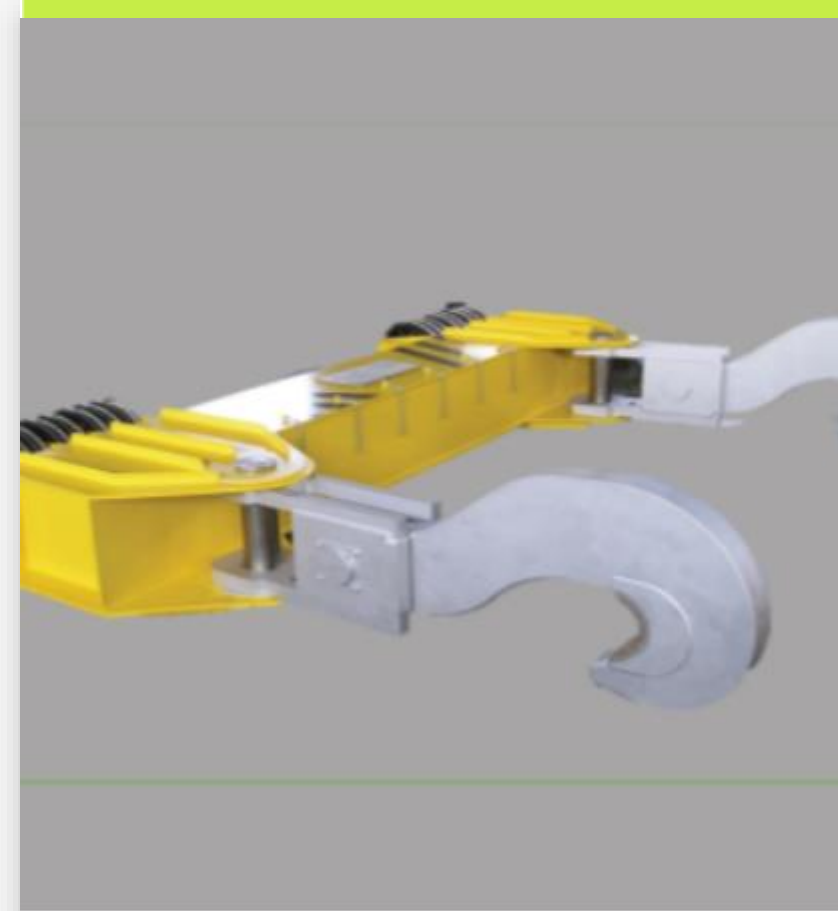
STEELMAKING PLANT**#1****#2****#3****#4****#1** 100Ton Electric Furnace**#2** 100Ton Electric Furnace Top Shell**#3** 120Ton Laminated Hook**#4** 75Ton Loading Cart

05

CERTIFICATIONS & STANDARDS

05 | CERTIFICATIONS & STANDARDS



<ISO9001:2015>



<ISO14001:2015>



<ISO45001:2015>



<건설업등록증>



<대구수출기업인증>



<직접생산확인증명서>



<기업부설연구소>



<중소기업확인서>

THANK YOU.

CONTACT US

● HEADQUARTERS

ADDRESS 86, DALSEONG 2-CHA 1-RO, GUJI-MYEON,
DALSEONG-GUN, DAEGU, KOREA

CONTACT 053-670-5541

FAX 053-670-5539

● PLANT 2

ADDRESS 227, GUKGASANDAN-DAERO 33-GIL, GUJI-
MYEON, DALSEONG-GUN, DAEGU, KOREA

CONTACT 053-670-5541

FAX 053-670-5539

● INQUIRY

WEBSITE <http://www.bm-i.co.kr>

E-MAIL bmifa@bm-i.co.kr

